



## RADIOMETER PHOTOMETER

### L-420



## INSTRUCTION MANUAL

PPUH **SONOPAN Sp. z o.o.**  
ul. Ciołkowskiego 2/2  
15-950 Białystok  
POLAND  
tel./fax: +48 85 742 36 62  
<http://www.sonopan.com.pl>

August 2012

# CONTENTS

1.	DESCRIPTION.....	3
1.1.	Meter marking .....	3
2.	CONNECTION TO THE MEASURING SYSTEM.....	4
2.1.	Strip connector description.....	4
2.2.	Coding switch description.....	4
2.3.	Configuration 1: using current loop interface.....	5
2.4.	Configuration 2: Using RS232 interface .....	5
2.4.1.	RS232 cable description .....	5
2.4.2.	Connection without RTS line .....	5
2.5.	Configuration 3: Using RS232 and current loop interfaces.....	5
3.	CALIBRATION .....	6
4.	CONTROL SOFTWARE .....	6
5.	TECHNICAL DATA .....	7
6.	ACCESSORIES .....	7
6.1.	Basic accessories .....	7
6.2.	Additional accessories.....	7
7.	RECOMENDATIONS FOR INSTRUMENT USE.....	7
8.	CE MARKING AND CONFORMANCE TO EU COUNCIL DIRECTIVES .....	8

# 1. DESCRIPTION

L-420 Radiometer photometer is a hardware platform designed for building optical radiation measurement system.

Depending on version it can be used to measure:

- illuminance,
- irradiance,
- photon irradiance,
- luminance,
- radiance,
- photon radiance.

Radiometer photometer L-420 can work with 4 – 20mA current loop analog interface (result read-only), or RS232 digital interface (device control and reading the result). RS232 interface allows to control using manufacturer's protocol SONBUS or standard MODBUS RTU protocol. Detailed descriptions of both protocols for data exchange are provided with the instrument in the form of PDF files. The device is powered via the current loop, even when using only the RS232 port. To proper work, RTS signal in RS232 interface should be set active. Current loop can be disabled by the user. In this case, current in the loop does not depend on measured result.

Measured quantity is averaged by moving average filter, which length can be set in the following range: 1 to 64 subsequent analog to digital conversions. Duration of a single conversion is 160ms. In addition, minimum and maximum values of single conversion included in moving average can be read by RS232 interface.

L-420 is equipped with an internal temperature sensor. The device automatically compensates temperature influence on the result and. When current loop is enabled, meter automatically carried out measuring system zeroing when temperature changes by 5°C. Zeroing procedure takes 3 seconds. During this time, the last measured value is returned as the result, and information about the zeroing status is provided in the status (see transmission protocol). It is possible to start measuring system zeroing using remote command. The new zeroing factor is not stored and will be lost after reset. Transmission protocol includes a command which allows storing this coefficient in non-volatile memory.

## 1.1. Meter marking

Exact type name of L-420 radiometer photometer is build from its specification. It consists of:

- meter name: **L-420** (constant),
- spectral sensitivity, depends of meter type, e. g.:
  - **V** :  $V(\lambda)$  sensitivity, Photometer,
  - **V'** :  $V'(\lambda)$  sensitivity, Photometer,
  - **BLH** :  $B(\lambda)$  sensitivity (*Blue Light Hazard*), Radiometer,
  - **PAR** : Photosynthetically Active Radiation sensitivity, Photon radiometer,
- value of highest measuring range in the basic unit of measured quantity,
- meter type:
  - **E** : illuminance / irradiance / photon irradiance meter,
  - **L $\alpha$ u** : luminance / radiance / photon radiance meter,
    - $\alpha$** : field aperture,
    - u**: field aperture unit (°, ', "),
- meter configuration,
- manufacturing version (optional).

Fields described above are separated by „/”

Examples:

- L-420/V/500k/L3°0 indicates:
  - L-420 : L-420 radiometer photometer,

V : photometer, photopic spectral sensitivity,  
 500k : highest measuring range 500 000 cd·m<sup>-2</sup>,  
 L3° : luminance / radiance / photon radiance meter, field aperture 3°,  
 0 : configuration 0,  
 basic manufacturing version (no additional marking).

- L-420/V'/500k/E/1/2 indicates:
  - L-420 : L-420 radiometer photometer,
  - V' : photometer, scotopic spectral sensitivity,
  - 500k : highest measuring range 500 000 lx,
  - E : illumination meter,
  - 1 : configuration 1,
  - 2 : manufacturing version 2.

## 2. CONNECTION TO THE MEASURING SYSTEM

Connection panel, which allows connection to other elements of measuring system (e.g. programmable logic controller, power supply unit, PC computer) is available by unscrewing and removing the back cover of the meter. There is a strip connector and coding switch.

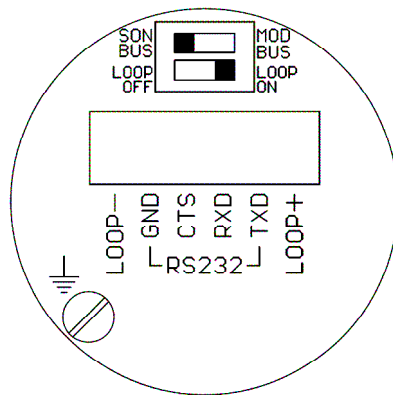

Fig. 1. Connection panel view.

Strip connector consists of a socket and plug, which is fastened to cable wires. The cable should be postponed by a culvert, wires should be attached to the plug. Then the culvert should be tighten and back cover can be screwed.

### 2.1. Strip connector description

1. LOOP-: current loop minus / power supply minus.
2. GND : RS232 ground.
3. CTS : RS232 power supply (should be connected to RTS line in master device).
4. RXD : RS232 receive data (should be connected to TXD line in master device).
5. TXD : RS232 transmit data (should be connected to RXD line in master device).
6. LOOP+: current loop plus / power supply plus.

### 2.2. Coding switch description

SONBUS : SONBUS protocol selected.  
 MODBUS : MODBUS RTU protocol selected.  
 LOOPOFF : current loop turned off.  
 LOOPON : current loop turned on.

## 2.3. Configuration 1: using current loop interface

To connect the instrument to the measurement system unscreened cable with a maximum diameter of 5mm should be used. This cable should be wound one turn on splitted ferrite core supplied with the unit, and the core should be placed as close to the meter as possible.

Coding switch should be set in position LOOPON.

## 2.4. Configuration 2: Using RS232 interface

To connect the instrument to the measuring system cable LIYCY 6x0,14 QMM (manufactured by TECHNOKABEL, <http://www.technokabel.com.pl>) or equivalent should be used. The cable shield should be connected to the DB9F connector plug housing, and to L-420 housing with screw marked with the symbol  $\perp$  located near the culvert.

### 2.4.1. RS232 cable description

Colors only concerns cable supplied by manufacturer.

RS232 port	Color	L-420	Strip connector
GND	yellow	GND	2
RTS	gray	CTS	3
TXD	green	RXD	4
RXD	brown	TXD	5
housing	screen	housing	–

Socket DC 2,1/5,5	Color	L-420	Strip connector
sleeve	white	LOOP–	1
pin	pink	LOOP+	6

To power L-420 radiometer – photometer an AC adapter with fixed output voltage from range 9 to 24V DC and DC 2,1/5,5 plug should be used.

Coding switch should be set in position LOOPOFF and SONBUS or MODBUS position should be selected (for L-420 software SONBUS protocol should be set).

**WARNING** If current loop is turned off, automatic measuring system zeroing is also turned off. This operation can be made on remote command.

### 2.4.2. Connection without RTS line

On the strip connector, connections must be bridged: 1 (LOOP–) with 2 (GND), and 3 (CTS) with 6 (LOOP+). RTS line from controller port stay unconnected.

**WARNING:** In this case, current loop interface will not work properly, then it should be turned off.

Supply voltage must not exceed 12V (higher voltage will damage interface).

## 2.5. Configuration 3: Using RS232 and current loop interfaces

RS232 interface should be connected as described in section 2.4. Meter may be powered from external power supply unit, with ammeter attached in series or from programmable logic controller.

Coding switch should be set in position LOOPOFF and SONBUS or MODBUS position should be selected (for L-420 software SONBUS protocol should be set).

### 3. CALIBRATION

To calibrate radiometer – photometer configuration described in section 2.5 should be set up. Configuration is shown in the figure below.

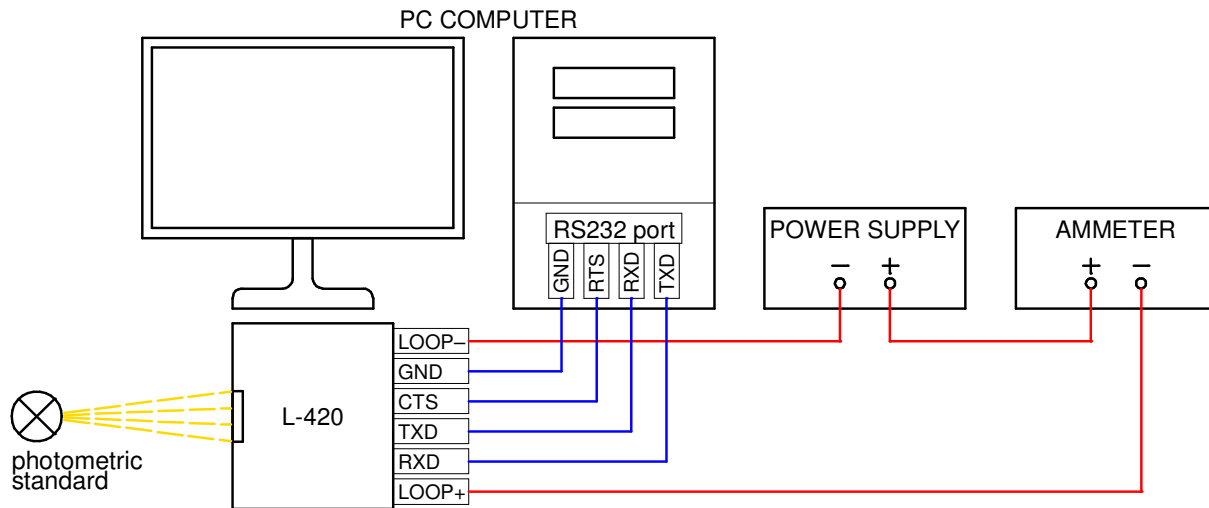

Fig. 2. Configuration used to calibrate the meter.

Calibration can be performed using software supplied with the device. It should then follow the instructions contained in the program. In case of using own application to conduit the calibration, calibration procedure is described in attached PDF file.

### 4. CONTROL SOFTWARE

With the L-420 radiometer – photometer manufacturer provides L420 computer program. It requires Windows operating system. The device must be connected to RS232 serial communication port or PC USB port using the USB-RS232/DB9 adapter. Communication with the meter is carried out using SONBUS protocol, so coding switch on the connection panel should be properly set up.

L420 software allows:

- reading of measured quantity,
- changing measuring range,
- additional (independent of set in the meter) averaging subsequent readings and setting up the number of this readings,
- logging minimum and maximum value of single conversion from all readings,
- creating measurement history log, its archiving and exporting to spreadsheet,
- creating calibration history log.
- zeroing detector,
- zeroing measuring system (meter only),
- changing SONBUS / MODBUS RTU address,
- selecting default measuring range (which will be set up after power up the meter),
- setting up length of moving average filter in the meter,
- meter calibration.

## 5. TECHNICAL DATA

- Supply voltage (stabilized): +9 do +30V.
- Absolute maximum supply voltage: +24V (unstabilized), +36V (stabilized).
- Current consumption:
  - 3.5mA to 22mA with current loop turned on (current depends on measured value),
  - 4mA with current loop turned off.
- Length of moving average filter: 1 to 64.
- Duration of single conversion: 160ms ±50ppm.
- Digital reading resolution: 17 bits.
- Current loop resolution: 16 bits.
- Maximum number of measuring ranges: 3.
- Class of protection: IP65 (IP68 available on special order).
- Dimensions: Ø44 × 80mm.

Other parameters are dependent on meter specifications and are delivered in a separate sheet, except that if the parameters are repeated, it is applicable are those of the specification sheet of a particular instrument.

## 6. ACCESSORIES

### 6.1. Basic accessories

- Mounting bracket with threaded holes 3/8" and M4.
- No. 5 allen wrench for locking device in the bracket.
- Strip connector plug, type MC1,5/6-ST-3,5 (Phoenix Contacts).
- Screwdriver to attach the cable wires with plug.
- Instruction manual.
- L420 software.

### 6.2. Additional accessories

- RS232 cable.
- External power supply 9V DC.

## 7. RECOMENDATIONS FOR INSTRUMENT USE

- Do not expose instrument on fall, strong shocks or other factors that could cause mechanical damage.
- Optical elements can be cleared using soft cloth moistened with pure alcohol. In case of heavy pollution can be pre-use warm water with detergent.
- An o-ring type seal should be lubricated with silicone grease and inner surface of the housing and threads should be free of dirt.
- To maintain protection class, cable culvert should be securely tightened.
- For installing the device, use the handle supplied with the instrument.
- The instrument should be stored and transported in a factory package.
- The instrument always should be sealed – both covers tightened and the cable or rod supplied by the manufacturer, should be placed in the cable culvert.
- Any repairs must be performed by manufacturer.

## 8. CE MARKING AND CONFORMANCE TO EU COUNCIL DIRECTIVES

The product described in this instruction manual conforms to following EU Council Directives:

2004/108/EC Electromagnetic Compatibility (EMC).



The conformation to above-mentioned requirements is confirmed by CE mark.



This product cannot be thrown away with household waste. Deposit the product in an authorized electrical and electronic waste collection area for recycling. Contact local Municipal Bureau or nearest waste disposal company to get more detailed information.



# DECLARATION OF CONFORMITY **CE**

no 1/2011

Manufacturer: PPUH „SONOPAN” Sp. z o. o.  
Address: 15- 950 Białystok, ul. Ciołkowskiego 2/2  
phone: +48 85 742 36 62  
Product: Radiometer – photometer  
Type: L-420

The product described above, is in conformity with following directives:  
2004/108/EC

Compliance was confirmed based on the results of required tests.

Additional documents:

Test report no: BE/293/2011  
Test report no: EMC L-420/1/2011

Białystok, 2011.07.11

.....  
(place and date of issue)

PREZES ZARZĄDU  
SONOPAN Sp. z o.o.  
DYREKTOR

*mgr inż. Sławomir Antoni Więcko*

.....  
(stamp and signature of authorized person)